



ENVASES SANZ BELDA, S.L.

Tel.: 34 96 236 02 32 - calidad@envasesanzbelda.es - www.envasesanzbelda.es
Pol. Ind. San José. Avda, Valencia, parc. 7 - Apdo. de Correos 46 - 46812 Aielo de Malferit. Valencia. (España)



Technical comercial data ref.

M.N-7.5 T.M-10-O

Serie MASTER NOVA – Versión 26-07-2023

Lid with screw shutter cap

TECHNICAL DATA:

Material:	PP copolymer of first quality, suitable for contact with food according to current regulations.
Colours:	White standard. Consult for other colours.
Weight of the bucket:	7.5 litres
Volume to the edge:	9.8 litres
Weight of the bucket:	301 g. approx.
Weight of the lid(with berg):	141 g. approx.
Weight of the handle (plastic):	26 g. approx.
Total Weight:	468 g. approx.
Decorative surface flat inks:	140 x 779 mm (height x perimeter)
Design surface photographic finish:	140 x 795 mm (height x perimeter)



MEASUREMENTS:

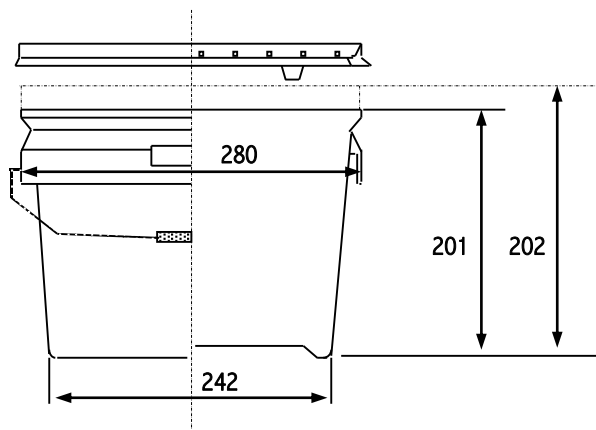

Measurements in millimetres

GROUPING OF TRANSPORT:

Buckets:	480 buckets per pallet
Pallet dimensions:	1150 x 850 x 1680 (see drawing)
Lids:	60 lids per bag, this serves as a packaging of transportation
Bag dimension:	280 x 810

